

# Test Report

Applicant: SHENZHEN TVT DIGITAL TECHNOLOGY CO., LTD.

Product Name: DVR

Brand Name: TVT

Model No.: TD-2708NS-HC, TD-2704NS-HC, TD-2704BS-HC, TD-2704BS-HC-A, TD-2708BS-HC, TD-2708BS-HC-A, TD-2704TS-HC, TD-2708TS-HC, TD-2704NS-HP, TD-2704BS-HP, TD-2704BS-HP-A, TD-2704TS-HP, TD-2708TS-HP, TD-2116NS-HC, TD-2104NS-HC, TD-2108NS-HC, TD-2116NS-HC-H, TD-2104NS-HP, TD-2108NS-HP, TD-2108NS-HP-H, TD-2104BS-HC, TD-2108BS-HC, TD-2116BS-HC, TD-2104BS-HP, TD-2108BS-HP, TD-2104TS-HC, TD-2108TS-HC, TD-2116TS-HC, TD-2104TS-HP, TD-2108TS-HP, TD-2116NS-HL, TD-2004NS-HL, TD-2008NS-HL, TD-2004BS-HL, TD-2008BS-HL, TD-2116BS-HL, TD-2004TS-HL, TD-2008TS-HL, TD-2116TS-HL, TD-2004NS-HL-L, TD-2008NS-HL-L, TD-2004NS-HL-H, TD-2008NS-HL-H, TD-2116NS-HL-H, TD-2104NS-HC-H, TD-2108NS-HC-H, TD-2704NS-HC-H, TD-2708NS-HC-H, TD-2104NS-HP-H, TD-2704NS-HP-H, TD-2004NS-HL-B, TD-2008NS-HL-B, TD-2116NS-HL-B, TD-27xxyS-Hy, TD-27xxyS-Hy-y, TD-21xxyS-Hy, TD-21xxyS-Hy-y, TD-20xxyS-Hy, TD-20xxyS-Hy-y (x= 0-9, or blank; y = A-Z, or blank)

Remark: There are some differences in appearance, color, screen printing and structure between models, and the internal key hardware is consistent without affecting EMC.  
Provision updates the Model No. base on the original report No. MTEG22071735

Date of Receipt : /

Date of Test: Sep.02-10,2021

Date of Report: Aug.01,2023

Prepared by: Shenzhen Most Technology Service Co., Ltd.

**The EMC testing has been performed on the submitted samples and found in compliance with the council EMC directive 2014/30/EU.**

Shenzhen Most Technology Service Co., Ltd.  
No.5, 2nd Langshan Road, North District, Hi-tech Industry Park,  
Nanshan, Shenzhen, Guangdong, China  
Phone: 86-755-86026850  
Fax: 86-755-26013350  
[http:// www.szmost.com](http://www.szmost.com)





# TABLE OF CONTENTS

Description	Page
Test Report Declaration.....	4
<b>1. GENERAL INFORMATION.....</b>	<b>5</b>
1.1. Description of Device (EUT).....	5
1.2. Operational Mode(s) of EUT.....	5
1.3. Test Voltage(s) of EUT.....	5
<b>2. DESCRIPTION OF TEST STANDARD.....</b>	<b>6</b>
<b>3. LABORATORY INFORMATION.....</b>	<b>7</b>
3.1. Laboratory Name.....	7
3.2. Location.....	7
3.3. Test facility.....	7
3.4. Measurement Uncertainty.....	7
<b>4. SUMMARY OF TEST RESULTS.....</b>	<b>8</b>
<b>5. BLOCK DIAGRAM OF TEST SETUP.....</b>	<b>9</b>
5.1. Block Diagram of connection between EUT and simulation-EMI.....	9
5.2. Block Diagram of connection between EUT and simulation-EMS.....	9
<b>6. TEST INSTRUMENT USED.....</b>	<b>10</b>
6.1. For Conducted Disturbance at Mains Terminals Emission Test.....	10
6.2. For Conducted Disturbance at Telecommunication Port Terminals Test.....	10
6.3. For Radiation Test (In Anechoic Chamber)(Below 1000MHz).....	10
6.4. For Radiation Test (In Anechoic Chamber)(Above 1000MHz).....	11
6.5. For Harmonic / Flicker Test.....	11
6.6. For Electrostatic Discharge Immunity Test.....	11
6.7. For RF Strength Susceptibility Test.....	11
6.8. For Electrical Fast Transient/Burst Immunity Test.....	12
6.9. For Surge Test.....	12
6.10. For Injected Currents Susceptibility Test.....	12
6.11. For Magnetic Field Immunity Test.....	12
6.12. For Voltage Dips and Interruptions Test.....	12
<b>7. CONDUCTED DISTURBANCE AT MAINS TERMINALS TEST.....</b>	<b>13</b>
7.1. Configuration of Test System.....	13
7.2. Test Standard.....	13
7.3. Power Line Conducted Disturbance at Mains Terminals Limit.....	13
7.4. Test Procedure.....	13
7.5. Conducted Disturbance at Mains Terminals Test Results.....	14
<b>8. CONDUCTED DISTURBANCE AT TELECOMMUNICATION PORTS TERMINALS TEST</b>	<b>15</b>
8.1. Configuration of Test System.....	15
8.2. Test Standard.....	15
8.3. Conducted Disturbance at Telecommunication port Limit.....	15
8.4. Operating Condition of EUT.....	15
8.5. Test Procedure.....	16
8.6. Conducted Disturbance At Telecommunication Ports Terminals Test Results.....	16
<b>9. RADIATED DISTURBANCE TEST.....</b>	<b>17</b>
9.1. Configuration of Test System.....	17
9.2. Test Standard.....	17
9.3. Radiated Disturbance Limit.....	18
9.4. Test Procedure.....	18
9.5. Radiated Disturbance Test Results.....	18
<b>10. HARMONIC CURRENT TEST.....</b>	<b>19</b>
10.1. Configuration of Test System.....	19
10.2. Test Standard.....	19
10.3. Test Limits.....	19

10.4.	Test Results .....	19
<b>11.</b>	<b>VOLTAGE FLUCTUATIONS &amp; FLICKER TEST .....</b>	<b>20</b>
11.1.	Configuration of Test System .....	20
11.2.	Test Standard .....	20
11.3.	Test Limits .....	20
11.4.	Test Results .....	20
<b>12.</b>	<b>IMMUNITY PERFORMANCE CRITERIA .....</b>	<b>22</b>
<b>13.</b>	<b>ELECTROSTATIC DISCHARGE IMMUNITY TEST .....</b>	<b>23</b>
13.1.	Configuration of Test System .....	23
13.2.	Test Standard .....	23
13.3.	Severity Levels and Performance Criterion .....	24
13.4.	Test Procedure .....	24
13.5.	Test Results .....	24
<b>14.</b>	<b>RF FIELD STRENGTH SUSCEPTIBILITY TEST .....</b>	<b>26</b>
14.1.	Configuration of Test System .....	26
14.2.	Test Standard .....	26
14.3.	Severity Levels and Performance Criterion .....	26
14.4.	Test Procedure .....	27
14.5.	Test Results .....	27
<b>15.</b>	<b>ELECTRICAL FAST TRANSIENT/BURST IMMUNITY TEST .....</b>	<b>29</b>
15.1.	Configuration of Test System .....	29
15.2.	Test Standard .....	29
15.3.	Severity Levels and Performance Criterion .....	29
15.4.	Test Procedure .....	30
15.5.	Test Results .....	30
<b>16.</b>	<b>SURGE TEST .....</b>	<b>32</b>
16.1.	Configuration of Test System .....	32
16.2.	Test Standard .....	32
16.3.	Severity Levels and Performance Criterion .....	32
16.4.	Test Procedure .....	33
16.5.	Test Results .....	33
<b>17.</b>	<b>INJECTED CURRENTS SUSCEPTIBILITY TEST .....</b>	<b>35</b>
17.1.	Configuration of Test System .....	35
17.2.	Test Standard .....	35
17.3.	Severity Levels and Performance Criterion .....	35
17.4.	Test Procedure .....	36
17.5.	Test Results .....	36
<b>18.</b>	<b>MAGNETIC FIELD IMMUNITY TEST .....</b>	<b>38</b>
18.1.	Configuration of Test System .....	38
18.2.	Test Standard .....	38
18.3.	Severity Levels and Performance Criterion .....	38
18.4.	Test Procedure .....	39
18.5.	Test Results .....	39
<b>19.</b>	<b>VOLTAGE DIPS AND INTERRUPTIONS TEST .....</b>	<b>41</b>
19.1.	Configuration of Test System .....	41
19.2.	Test Standard .....	41
19.3.	Severity Levels and Performance Criterion .....	41
19.4.	Test Procedure .....	42
19.5.	Test Results .....	42

APPENDIX I	(2 pages)
APPENDIX II	(1 page)
APPENDIX III	(2 pages)
APPENDIX IV (Test Photos)	(2 pages)
APPENDIX V (Photos of the EUT)	(5 pages)

# TEST REPORT DECLARATION

Report Number	MTEG22071735/1	
Applicant	SHENZHEN TVT DIGITAL TECHNOLOGY CO., LTD.	
	23rd Floor Building B4 Block 9, Shenzhen Bay science and technology ecological garden, Nanshan District, Shenzhen, P.R. China	
Manufacturer	SHENZHEN TVT DIGITAL TECHNOLOGY CO., LTD.	
	23rd Floor Building B4 Block 9, Shenzhen Bay science and technology ecological garden, Nanshan District, Shenzhen, P.R. China	
Product	Product Name	DVR
	Model No.	TD-2708NS-HC
	Power Supply	DC 12V by Adapter
Test Result	The EUT was found compliant with the requirement(s) of the standards.	
Standard	EN 55032:2015+A1:2020, EN IEC 61000-3-2:2019+A1:2021, EN 61000-3-3:2013+A1:2019+A2:2021 EN 55035:2017+A11:2020(IEC 61000-4-2:2008, IEC 61000-4-3:2006+A1:2007+A2:2010, IEC 61000-4-4:2012, IEC 61000-4-5:2005, IEC 61000-4-6:2008, IEC 61000-4-8:2009, IEC 61000-4-11:2004)	
<p><b>*Note</b></p> <p>The above device has been tested by Shenzhen Most Technology Service Co., Ltd. To determine the maximum emission levels emanating from the device and the severe levels of the device can endure and its performance criterion. The test record, data evaluation &amp; Equipment Under Test (EUT) configurations represented are contained in this test report and Shenzhen Most Technology Service Co., Ltd. Is assumed full responsibility for the accuracy and completeness of test. Also, this report shows that the EUT is technically compliant with the requirement of the above standards.</p> <p>This report applies to above tested sample only. This report shall not be reproduced except in full, without written approval of Shenzhen Most Technology Service Co., Ltd., this document may be altered or revised by Shenzhen Most Technology Service Co., Ltd., personal only, and shall be noted in the revision of the document.</p>		
Prepared by	 Alisa Luo(Engineer)	
		
Reviewed by	 Sunny Deng (Engineer)	
Approved by	 Yvette Zhou(Manager)	

# 1. GENERAL INFORMATION

## 1.1. Description of Device (EUT)

Description	:	DVR
Model Number	:	TD-2708NS-HC, TD-2704NS-HC, TD-2704BS-HC, TD-2704BS-HC-A, TD-2708BS-HC, TD-2708BS-HC-A, TD-2704TS-HC, TD-2708TS-HC, TD-2704NS-HP, TD-2704BS-HP, TD-2704BS-HP-A, TD-2704TS-HP, TD-2708TS-HP, TD-2116NS-HC, TD-2104NS-HC, TD-2108NS-HC, TD-2116NS-HC-H, TD-2104NS-HP, TD-2108NS-HP, TD-2108NS-HP-H, TD-2104BS-HC, TD-2108BS-HC, TD-2116BS-HC, TD-2104BS-HP, TD-2108BS-HP, TD-2104TS-HC, TD-2108TS-HC, TD-2116TS-HC, TD-2104TS-HP, TD-2108TS-HP, TD-2116NS-HL, TD-2004NS-HL, TD-2008NS-HL, TD-2004BS-HL, TD-2008BS-HL, TD-2116BS-HL, TD-2004TS-HL, TD-2008TS-HL, TD-2116TS-HL, TD-2004NS-HL-L, TD-2008NS-HL-L, TD-2004NS-HL-H, TD-2008NS-HL-H, TD-2116NS-HL-H, TD-2104NS-HC-H, TD-2108NS-HC-H, TD-2704NS-HC-H, TD-2708NS-HC-H, TD-2104NS-HP-H, TD-2704NS-HP-H, TD-2004NS-HL-B, TD-2008NS-HL-B, TD-2116NS-HL-B, TD-27xxyS-Hy, TD-27xxyS-Hy-y, TD-21xxyS-Hy, TD-21xxyS-Hy-y, TD-20xxyS-Hy, TD-20xxyS-Hy-y (x= 0-9, or blank; y = A-Z, or blank)
Remark	:	Used TD-2708NS-HC does all tests

## 1.2. Operational Mode(s) of EUT

Order Number	:	Test Mode(s)
1	:	Running
2	:	Ping

## 1.3. Test Voltage(s) of EUT

Order Number	:	Test Voltage(s)
1	:	DC 12V by Adapter

## 2. DESCRIPTION OF TEST STANDARD

The intention of this publication is to establish uniform requirements for the radio disturbance level of the equipment contained in the scope, to fix limits of disturbance, to describe methods of measurement and to standardize operating conditions and interpretation of results.

The following referenced standard are indispensable for the application of this report.

Referenced Description below:

EN 55032:2015+A1:2020

Information Technology Equipment-Radio disturbance characteristics-Limits and methods of measurement.

EN IEC 61000-3-2:2019+A1:2021

Limits for harmonic current emissions (equipment input current  $\leq 16$  A per phase).

EN 61000-3-3:2013+A1:2019+A2:2021

Limitation of voltage changes, voltage fluctuations and flicker in public low-voltage supply systems, for equipment with rated current  $\leq 16$  A per phase and not subject to conditional connection.

EN 55035:2017+A11:2020

Information technology equipment - Immunity characteristics - Limits and methods of measurement.

### 3. LABORATORY INFORMATION

#### 3.1.Laboratory Name

Shenzhen Most Technology Service Co., Ltd.

#### 3.2.Location

No.5, 2nd Langshan Road, North District, Hi-tech Industrial Park, Nanshan, Shenzhen, Guangdong, China

#### 3.3.Test facility

- 3m Anechoic Chamber : Nov. 28, 2012 File on Federal Communication Commission  
Registration Number:490827
  
- Shielding Room : Nov. 28, 2012 File on Federal Communication Commission  
Registration Number:490827
  
- EMC Lab. : Accredited by TUV Rheinland Shenzhen  
Audit Report: UA 50149851  
Mar. 12, 2009  
  
 Accredited by Industry Canada  
 Registration Number: 7103A-1  
 Oct. 22, 2012  
  
 Accredited by TIMCO  
 Registration Number: Q1460  
 March 28, 2010

#### 3.4.Measurement Uncertainty

No.	Item	Uncertainty
1.	Uncertainty for Conducted Disturbance Test	1.25dB
2.	Uncertainty for Radiated Disturbance Test	3.15dB

#### 4. SUMMARY OF TEST RESULTS

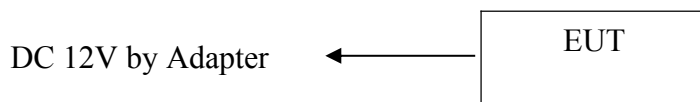
<b>EMISSION</b>			
<b>Test Item</b>	<b>Standard</b>	<b>Limits</b>	<b>Results</b>
Conducted disturbance at mains terminals	EN 55032:2015+A1:2020	Class B	PASS
Conducted disturbance at telecommunication ports terminals test	EN 55032:2015+A1:2020	Class B	PASS
Radiated disturbance	EN 55032:2015+A1:2020	Class B	PASS
Harmonic current emissions	EN IEC 61000-3-2:2019+A1:2021	Class D	N/A
Voltage fluctuations & flicker	EN 61000-3-3:2013+A1:2019 +A2:2021	---	PASS
<b>IMMUNITY (EN 55035:2017+A11:2020)</b>			
<b>Test Item</b>	<b>Basic Standard</b>	<b>Performance Criteria</b>	<b>Results</b>
Electrostatic discharge (ESD)	IEC 61000-4-2:2008	B	PASS
Radio-frequency, Continuous radiated disturbance	IEC 61000-4-3:2006 +A1:2007+A2:2010	A	PASS
Electrical fast transient (EFT)	IEC 61000-4-4:2012	B	PASS
Surge (Input a.c. power ports)	IEC 61000-4-5:2005	B	PASS
Surge (Telecommunication ports)		B	PASS
Radio-frequency, Continuous conducted disturbance	IEC 61000-4-6:2008	A	PASS
Power frequency magnetic field	IEC 61000-4-8:2009	A	PASS
Voltage dips, >95% reduction	IEC 61000-4-11:2004	B	PASS
Voltage dips, 30% reduction		C	PASS
Voltage interruptions		C	PASS
N/A is an abbreviation for Not Applicable.			



## 5. BLOCK DIAGRAM OF TEST SETUP

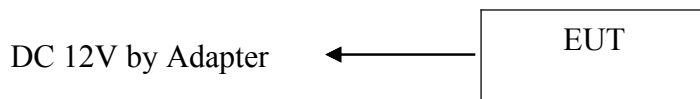
The equipments are installed test to meet EN 55032 requirement and operating in a manner which tends to maximize its emission characteristics in a normal application. EUT was tested in normal configuration (Please See following Block diagrams)

### 5.1. Block Diagram of connection between EUT and simulation-EMI



(EUT: DVR )

### 5.2. Block Diagram of connection between EUT and simulation-EMS



(EUT: DVR )

## 6. TEST INSTRUMENT USED

### 6.1. For Conducted Disturbance at Mains Terminals Emission Test

Item	Equipment	Manufacturer	Model No.	Serial No.	Last Cal.	Cal. Interval
1.	Test Receiver	Rohde & Schwarz	ESCI	100492	Mar. 05, 21	1 Year
2.	L.I.S.N.	Rohde & Schwarz	ENV216	100093	Mar. 05, 21	1 Year
3.	Coaxial Switch	Anritsu Corp	MP59B	6200283933	Mar. 05, 21	1 Year
4.	Terminator	Hubersuhner	50Ω	No.1	Mar. 05, 21	1 Year
5.	RF Cable	SchwarzBeck	N/A	No.1	Mar. 05, 21	1 Year

### 6.2. For Conducted Disturbance at Telecommunication Port Terminals Test

Item	Equipment	Manufacturer	Model No.	Serial No.	Last Cal.	Cal. Interval
1.	Test Receiver	Rohde & Schwarz	ESCS30	100340	Mar. 05, 21	1 Year
2.	L.I.S.N.	Rohde & Schwarz	ESH3-Z5	100317	Mar. 05, 21	1 Year
3.	Pulse Limiter	Rohde & Schwarz	ESH3-Z2	100168	Mar. 05, 21	1 Year
4.	RF Cable	FUJIKUSR	N/A	843 Cab11#	Mar. 05, 21	1 Year
5.	ISN	Tseq	T800	27597	Mar. 05, 21	1 Year

### 6.3. For Radiation Test (In Anechoic Chamber)(Below 1000MHz)

Item	Equipment	Manufacturer	Model No.	Serial No.	Last Cal.	Cal. Interval
1.	Test Receiver	Rohde & Schwarz	ESPI	101202	Mar. 05, 21	1 Year
2.	Bilog Antenna	Sunol	JB3	A121206	Mar. 05, 21	1 Year
3.	Cable	Resenberger	N/A	NO.1	Mar. 05, 21	1 Year
4.	Cable	SchwarzBeck	N/A	NO.2	Mar. 05, 21	1 Year
5.	Cable	SchwarzBeck	N/A	NO.3	Mar. 05, 21	1 Year
6.	DC Power Filter	DuoJi	DL2 30B	N/A	N/A	N/A
7.	Single Phase Power Line Filter	DuoJi	FNF 202B30	N/A	N/A	N/A
8.	3 Phase Power Line Filter	DuoJi	FNF 402B30	N/A	N/A	N/A

#### 6.4. For Radiation Test (In Anechoic Chamber)(Above 1000MHz)

Item	Equipment	Manufacturer	Model No.	Serial No.	Last Cal.	Cal. Interval
1	Spectrum Analyzer	Agilent	E4408B	MY414400460	Mar. 05, 21	1 Year
2	Pre-DVR	DCS	PAP-0118	24001	Mar. 05, 21	1 Year
3	Horn Antenna	Schwarzback	BBHA9120 D	D69250	Mar. 05, 21	1 Year
4	RF Cable	Schwarzback	LL142-10	RF Cable No.1	Mar. 05, 21	1 Year
5	RF Cable	Schwarzback	LL142-0.05	RF Cable No.2	Mar. 05, 21	1 Year
6	DC Power Filter	DuoJi	DL2030B	N/A	N/A	N/A
7	Single Phase Power Line Filter	DuoJi	FNF 202B30	N/A	N/A	N/A
8	3 Phase Power Line Filter	DuoJi	FNF 402B30	N/A	N/A	N/A

#### 6.5. For Harmonic / Flicker Test

Item	Equipment	Manufacturer	Model No.	Serial No.	Last Cal.	Cal. Interval
1.	AC Power Source	Kikusui	AC40MA	LM003232	Mar. 05, 21	1 Year
2.	Test Analyzer	Kikusui	KHA1000	LM003720	Mar. 05, 21	1 Year
3.	Line Impedance Network	Kikusui	LIN40MA-PCR-L	LM002352	Mar. 05, 21	1 Year

#### 6.6. For Electrostatic Discharge Immunity Test

Item	Equipment	Manufacturer	Model No.	Serial No.	Last Cal.	Cal. Interval
1.	ESD Tester	Zhongsheng	ESD-203AX	023K14538	Mar. 05, 21	1 Year

#### 6.7. For RF Strength Susceptibility Test

Item	Equipment	Manufacturer	Model No.	Serial No.	Last Cal.	Cal. Interval
1.	Signal Generator	IFR	2032	203002/100	Mar. 05, 21	1 Year
2.	DVR	A&R	150W1000	301584	NCR	NCR
3.	Dual Directional Coupler	A&R	DC6080	301508	Mar. 05, 21	1 Year
4.	Power Sensor	Anritsu	MA2491A	32263	Mar. 05, 21	1 Year
5.	Power Meter	R&S	NRVS	100444	Mar. 05, 21	1 Year
6.	Field Monitor	A&R	FM5004	300329	Mar. 05, 21	1 Year
7.	Field Probe	A&R	FP5000	300221	Mar. 05, 21	1 Year
8.	Log-periodic Antenna	A&R	AT1080	16512	Mar. 05, 21	1 Year
9.	RF Cable	MIYAZAKI	N/A	No.1/No.2	Mar. 05, 21	1 Year

### 6.8.For Electrical Fast Transient/Burst Immunity Test

Item	Equipment	Manufacturer	Model No.	Serial No.	Last Cal.	Cal. Interval
1.	EMCPRO System	EM Test	UCS-500-M4	V0648102026	Mar. 05, 21	1 Year

### 6.9.For Surge Test

Item	Equipment	Manufacturer	Model No.	Serial No.	Last Cal.	Cal. Interval
1.	EMCPRO System	EM Test	UCS-500-M4	V0648102026	Mar. 05, 21	1 Year

### 6.10.For Injected Currents Susceptibility Test

Item	Equipment	Manufacturer	Model No.	Serial No.	Last Cal.	Cal. Interval
1.	Signal Generator	IFR	2032	203002/100	Mar. 05, 21	1 Year
2.	DVR	A&R	150W1000	301584	NCR	NCR
3.	CDN	FCC	FCC-801-M2-25	47	Mar. 05, 21	1 Year
4.	CDN	FCC	FCC-801-M3-25	107	Mar. 05, 21	1 Year
5.	EM Injection Clamp	FCC	F-203I-23mm	403	Mar. 05, 21	1 Year
6.	RF Cable	MIYAZAKI	N/A	No.1/No.2	Mar. 05, 21	1 Year

### 6.11.For Magnetic Field Immunity Test

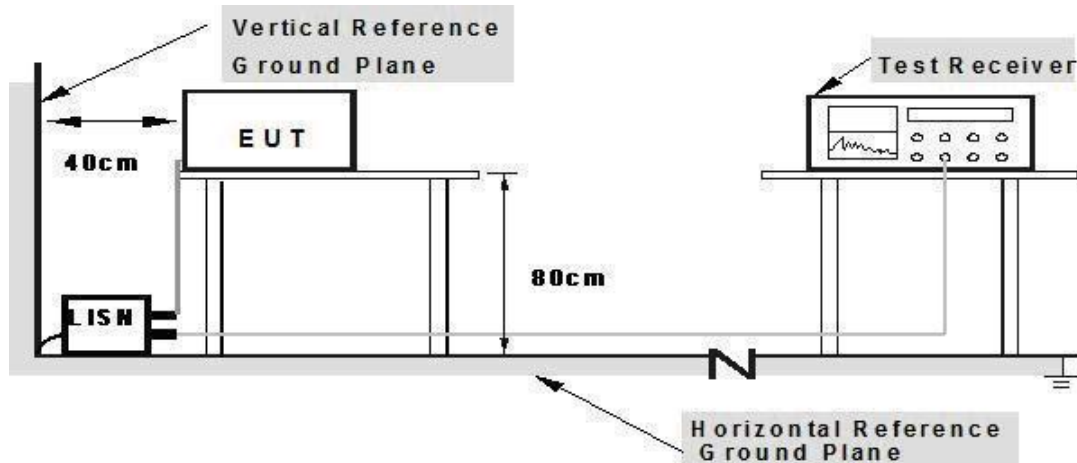
Item	Equipment	Manufacturer	Model No.	Serial No.	Last Cal.	Cal. Interval
1.	EMCPRO System	EM Test	UCS-500-M4	V0648102026	Mar. 05, 21	1 Year

### 6.12.For Voltage Dips and Interruptions Test

Item	Equipment	Manufacturer	Model No.	Serial No.	Last Cal.	Cal. Interval
1.	EMCPRO System	EM Test	UCS-500-M4	V0648102026	Mar. 05, 21	1 Year

## 7. CONDUCTED DISTURBANCE AT MAINS TERMINALS TEST

### 7.1. Configuration of Test System



**Note: 1. Support units were connected to second LISN.  
2. Both of LISNs (AMN) are 80 cm from EUT and at least 80 from other units and other metal planes**

### 7.2. Test Standard

EN 55032:2015+A1:2020

### 7.3. Power Line Conducted Disturbance at Mains Terminals Limit

Frequency	Maximum RF Line Voltage	
	Quasi-Peak Level dB( $\mu$ V)	Average Level dB( $\mu$ V)
150kHz ~ 500kHz	66 ~ 56*	56 ~ 46*
500kHz ~ 5MHz	56	46
5MHz ~ 30MHz	60	50

Notes: 1. \* Decreasing linearly with logarithm of frequency.

2. The lower limit shall apply at the transition frequencies.

### 7.4. Test Procedure

The EUT was placed on a non-metallic table, 80cm above the ground plane. The EUT Power connected to the power mains through a line impedance stabilization network (L.I.S.N. #1). This provided a 50-ohm coupling impedance for the EUT (Please refer to the block diagram of the test setup and photographs). The other peripheral devices power cord connected to the power mains through a line impedance stabilization network (L.I.S.N.#2). Both sides of power line were checked for maximum conducted interference. In order to find the maximum emission, the relative positions of equipments and all of the interface cables were changed according to EN 55032 Class B on conducted Disturbance test.

The bandwidth of test receiver is set at 9kHz.

The frequency range from 150kHz to 30MHz is checked. The test result are reported on Section 7.5.

## 7.5. Conducted Disturbance at Mains Terminals Test Results

7.5.1. Test Results: **PASS**

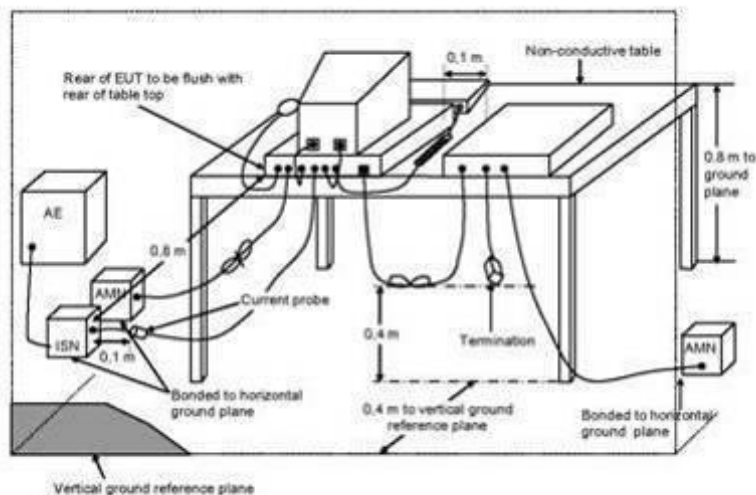
7.5.2. If the average limit is met when using a quasi-peak detector, the EUT shall be deemed to meet both limits and measurement with average detector is unnecessary.

7.5.3. Emission Level = Correct Factor + Reading Level.

7.5.4. The test data and the scanning waveform are attached within Appendix I.

## 8. CONDUCTED DISTURBANCE AT TELECOMMUNICATION PORTS TERMINALS TEST

### 8.1. Configuration of Test System



### 8.2. Test Standard

EN 55032:2015+A1:2020

### 8.3. Conducted Disturbance at Telecommunication port Limit

Frequency	Maximum RF Line Voltage	
	Quasi-Peak Level dB( $\mu$ V)	Average Level dB( $\mu$ V)
150kHz ~ 500kHz	84 to 74	74 to 64
500kHz ~ 30MHz	74	64

Notes: 1. The lower limit shall apply at the transition frequencies.

2. The limits decrease linearly with the logarithm of the frequency in the range 0.15 MHz to 0.5 MHz.

### 8.4. Operating Condition of EUT

#### 8.4.1. Environmental Conditions:

Ambient Temperature: 26°C, Relative Humidity: 60 %

#### 8.4.2. Setup the EUT and the simulators as shown on Section 5.1.

#### 8.4.3. Turn on the power of all equipments.

#### 8.4.4. Let the EUT work in test mode (Running PC System+ping) and test it.

## 8.5. Test Procedure

The EUT was placed on a non-metallic table, 80cm above the ground plane. ISN are used for measurements on telecom ports, they shall be nominally 0.8m from the EUT and bonded to a ground reference plane, other units of the equipment under test shall be at least 0.8m from the ISN, an ISN is connected to a telecommunications port during the measurement of conducted disturbances at the mains port, then ISN receiver port shall be terminated in 50-ohm and the LCL shall be representative of the telecommunications network to which that port attaches, In order to make reliable emission measurements representative of high LAN utilization it is only necessary to create a condition of LAN utilization in excess of 10% and sustain that and pseudo-random messages in order to emulate realistic types of data transmission. If the LAN maintains transmission during idle periods measurements shall also be made during idle periods.

The bandwidth of test receiver is set at 9 kHz.

The frequency range from 150kHz to 30MHz is checked. The test results are reported on Section 8.6.

## 8.6. Conducted Disturbance At Telecommunication Ports Terminals Test Results

8.6.1. Test Results: **PASS**

8.6.2. If the average limit is met when using a quasi-peak detector, the EUT shall be deemed to meet both limits and measurement with average detector is unnecessary.

8.6.3. Emission Level = Correct Factor + Reading Level.

8.6.4. The test data and the scanning waveform are attached within Appendix II.



## 9. RADIATED DISTURBANCE TEST

### 9.1. Configuration of Test System

#### Radiated Emission Test Set-Up Frequency Below 1 GHz

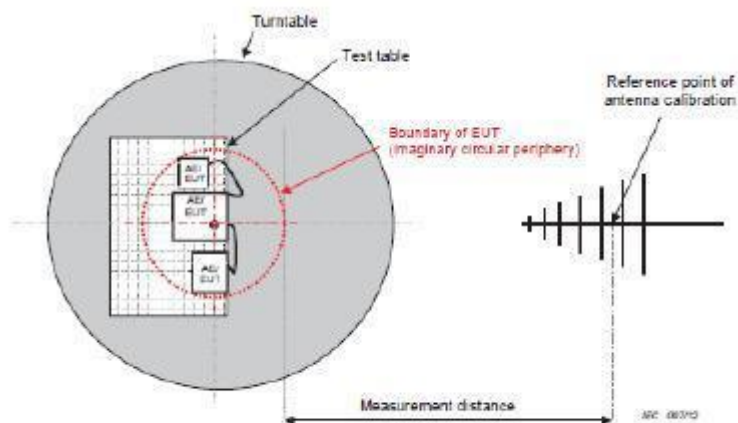


Figure C.1 – Measurement distance

#### Radiated Emission Test Set-Up Frequency Above 1GHz

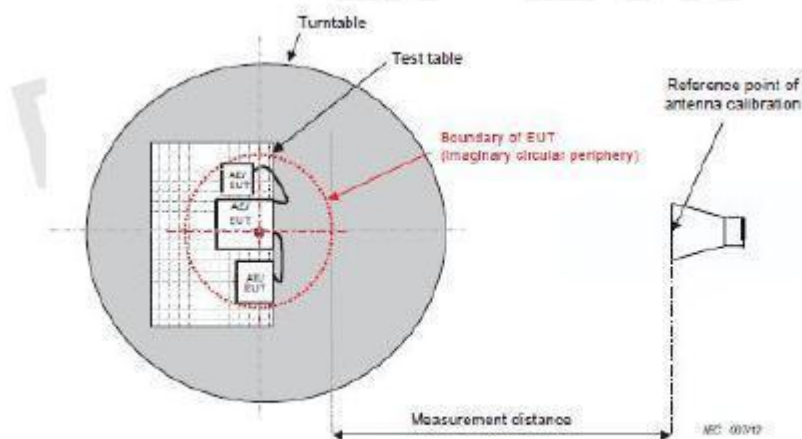


Figure C.1 – Measurement distance

### 9.2. Test Standard

EN 55032:2015+A1:2020

### 9.3. Radiated Disturbance Limit

All emanations from a Class B computing devices or system, including any network of conductors and apparatus connected thereto, shall not exceed the level of field strengths specified below:

FREQUENCY (MHz)	Distance (m)	Detector type/ bandwidth	Class A	Class B
			dBuV/m	dBuV/m
30 - 230	3	Quasi peak/ 120 kHz	50	40
230 - 1000	3	Quasi peak/ 120 kHz	57	47
1000-3000	3	Peak/1 MHz	76	70
3000-6000	3	Peak/1 MHz	80	74
1000-3000	3	AV/1 MHz	56	50
3000-6000	3	AV/1 MHz	60	54

Note: 1. The lower limit shall apply at the transition frequencies.

2. Distance refers to the distance in meters between the test antenna and the closed point of any part of the EUT.

### 9.4. Test Procedure

The EUT was placed on a non-metallic table, 80 cm above the ground plane inside a semi-anechoic chamber. An antenna was located 3m from the EUT on an adjustable mast. A pre-scan was first performed in order to find prominent radiated emissions. For final emissions measurements at each frequency of interest, the EUT were rotated and the antenna height was varied between 1m and 4m in order to maximize the emission. Measurements in both horizontal and vertical polarities were made and the data was recorded. In order to find the maximum emission, the relative positions of equipments and all of the interface cables were changed according to EN 55032 Class B on Radiated Disturbance test.

The bandwidth setting on the test receiver is 120 kHz. (frequency range from 30MHz to 1000MHz) and 1MHz (frequency range from 1000MHz to 6000MHz).

The frequency range from 30MHz to 6000MHz is checked. The test result are reported on Section 9.5.

### 9.5. Radiated Disturbance Test Results

9.5.1. Test Results: **PASS**

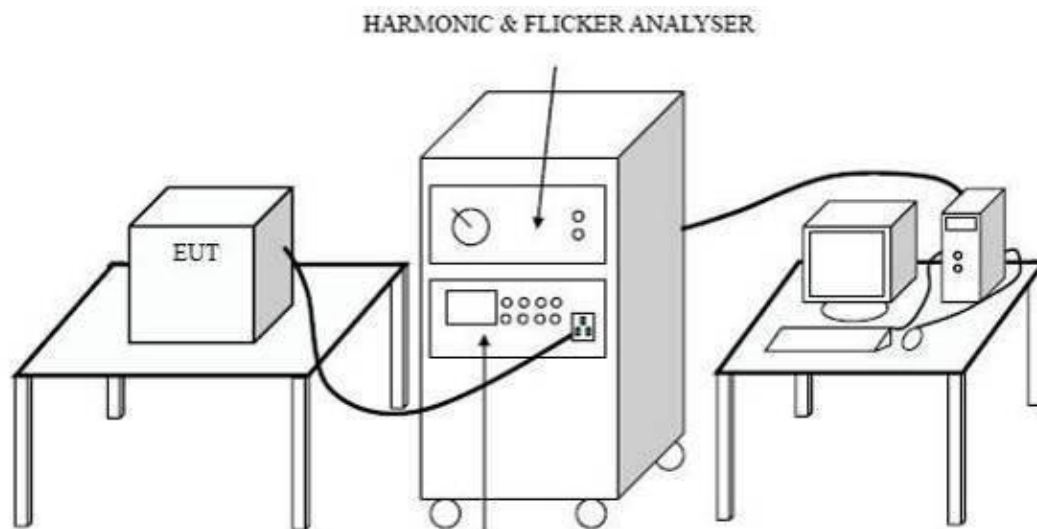
9.5.2. Emission Level= Correct Factor + Reading Level.

9.5.3. All reading are Quasi-Peak values.

9.5.4. The worst test data and the scanning waveform are attached within Appendix III.

## 10. HARMONIC CURRENT TEST

### 10.1. Configuration of Test System



### 10.2. Test Standard

EN IEC 61000-3-2:2019+A1:2021

### 10.3. Test Limits

For Class A equipment, the harmonics of the input current shall not exceed the values given in below:

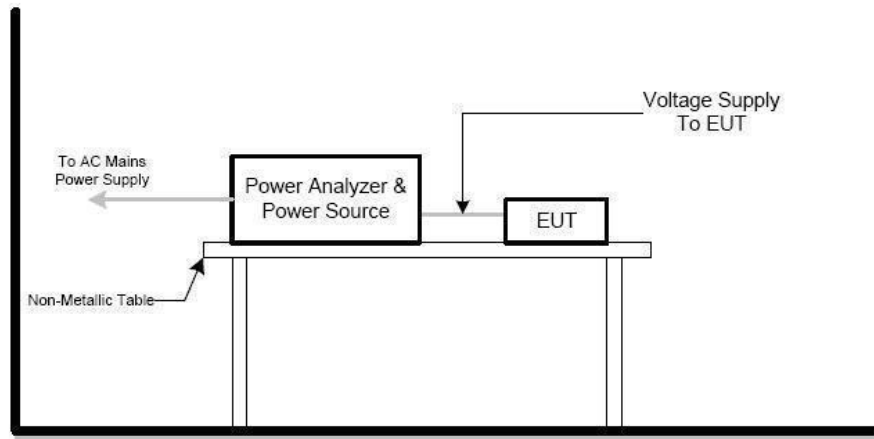
Harmonic order h	Maximum permissible harmonic current A
<b>Odd harmonics</b>	
3	2,30
5	1,14
7	0,77
9	0,40
11	0,33
13	0,21
$15 \leq h \leq 39$	$0,15 \frac{15}{h}$
<b>Even harmonics</b>	
2	1,08
4	0,43
6	0,30
$8 \leq h \leq 40$	$0,23 \frac{8}{h}$

### 10.4. Test Results

No limit apply for equipment with an active input power less than or equal to 75W.

# 11.VOLTAGE FLUCTUATIONS & FLICKER TEST

## 11.1.Configuration of Test System



## 11.2.Test Standard

EN 61000-3-3:2013+A1:2019+A2:2021

## 11.3.Test Limits

The limits shall be applicable to voltage fluctuations and flicker at the supply terminals of the equipment under test, the following limits apply:

the value of  $P_{st}$  shall not be greater than 1.0;

the value of  $P_{lt}$  shall not be greater than 0.65;

the value of  $d(t)$  during a voltage change shall not exceed 3.3% for more than 500ms;

the relative steady-state voltage change,  $d_c$ , shall not exceed 3.3%;

the maximum relative voltage change  $d_{max}$ , shall not exceed

a) 4% without additional conditions;

b) 6% for equipment which is:

Switched manually, or

Switched automatically more frequently than twice per day, and also has either a delayed restart (the delay being not less than a few tens of seconds), or manual restart, after a power supply interruption.

c) 7% for equipment which is

Attended whilst in use (for example: hair dryers, vacuum cleaners, kitchen equipment such as mixers, garden equipment such as lawn mowers, portable tools such as electric drills), or

switched on automatically, or is intended to be switched on manually, no more than twice per day, and also has either a delayed restart (the delay being not less than a few tens of seconds) or manual restart, after a power supply interruption.

## 11.4.Test Results

11.4.1.Test Results: **PASS**

EUT:	DVR	M/N:	TD-2708NS-HC
Mode:	Running	Power:	DC 12V by Adapter
Test by:	Peter	Test date:	2021-09-03
Temperature: / Humidity	24.0°C / 55.0%		

### Test Data of Voltage Fluction and Flicker

FINAL TEST RESULT **PASS**

Nominal Voltage	230V
Nominal Frequency	50Hz
Plt Test duration	630s
Flicker Margin	100%
d Measurement Margin	100%

	Pst	dc(%)	dmax(%)	d(t)>3.3%(ms)	Judge
Limit	1.000	3.300	4.000	500	
Seg. 1	0.007	0.004	0.026	0	Pass
Seg. 2	-,-,-,-	-,-,-,-	-,-,-,-	-,-,-,-	
Seg. 3	-,-,-,-	-,-,-,-	-,-,-,-	-,-,-,-	
Seg. 4	-,-,-,-	-,-,-,-	-,-,-,-	-,-,-,-	
Seg. 5	-,-,-,-	-,-,-,-	-,-,-,-	-,-,-,-	
Seg. 6	-,-,-,-	-,-,-,-	-,-,-,-	-,-,-,-	
Seg. 7	-,-,-,-	-,-,-,-	-,-,-,-	-,-,-,-	
Seg. 8	-,-,-,-	-,-,-,-	-,-,-,-	-,-,-,-	
Seg. 9	-,-,-,-	-,-,-,-	-,-,-,-	-,-,-,-	
Seg.10	-,-,-,-	-,-,-,-	-,-,-,-	-,-,-,-	
Seg.11	-,-,-,-	-,-,-,-	-,-,-,-	-,-,-,-	
Seg.12	-,-,-,-	-,-,-,-	-,-,-,-	-,-,-,-	

	Plt	Judge
Limit	0.650	
Measurement	0.003	Pass

## 12. IMMUNITY PERFORMANCE CRITERIA

The test results shall be classified in terms of the loss of function or degradation of performance of the equipment under test, relative to a performance level by its manufacturer or the requestor of the test, or the agreed between the manufacturer and the purchaser of the product.

Definition related to the performance level:

Based on the used product standard

Based on the declaration of the manufacturer, requestor or purchaser

Criterion A:

The equipment shall continue to operate as intended without operator intervention. No degradation of performance or loss of function is allowed below a performance level specified by the manufacturer when the equipment is used as intended. The performance level may be replaced by a permissible loss of performance. If the minimum performance level or the permissible performance loss is not specified by the manufacturer, then either of these may be derived from the product description and documentation, and by what the user may reasonably expect from the equipment if used as intended.

Criterion B:

After the test, the equipment shall continue to operate as intended without operator intervention. No degradation of performance or loss of function is allowed, after the application of the phenomena below a performance level specified by the manufacturer, when the equipment is used as intended. The performance level may be replaced by a permissible loss of performance. During the test, degradation of performance is allowed. However, no change of operating state or stored data is allowed to persist after the test. If the minimum performance level (or the permissible performance loss) is not specified by the manufacturer, then either of these may be derived from the product description and documentation, and by what the user may reasonably expect from the equipment if used as intended.

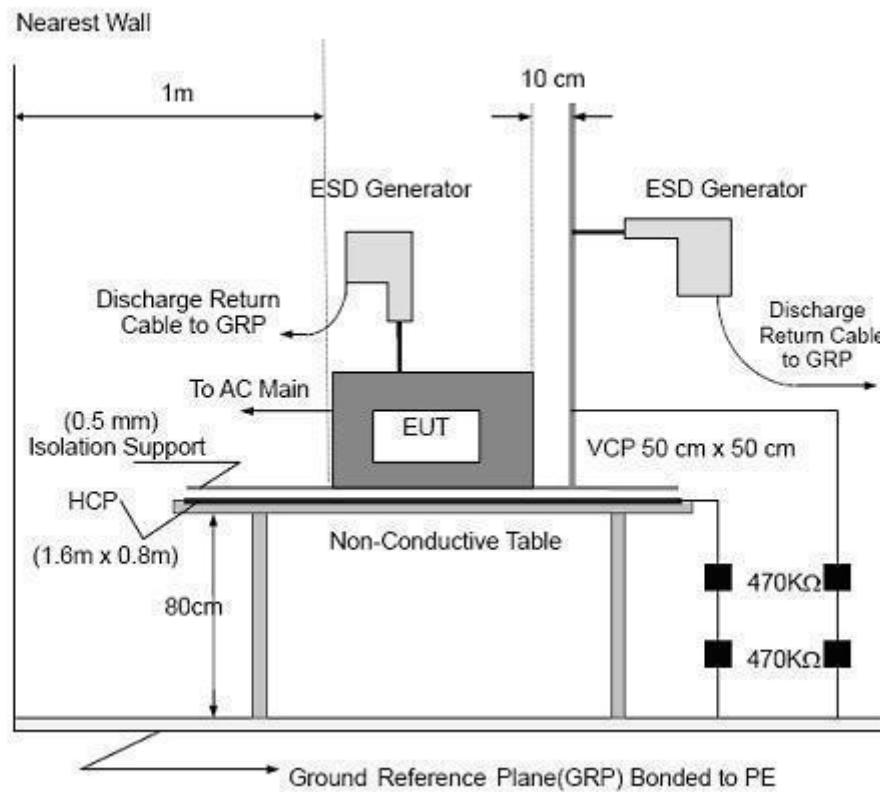
Criterion C:

Loss of function is allowed, provided the function is self-recoverable, or can be restored by the operation of the controls by the user in accordance with the manufacturer's instructions. Functions, and/or information stored in non-volatile memory, or protected by a battery backup, shall not be lost.

# 13.ELECTROSTATIC DISCHARGE IMMUNITY TEST

## 13.1.Configuration of Test System

### 13.1.1. TEST SETUP



## 13.2.Test Standard

EN 55035:2017+A11:2020(IEC 61000-4-2:2008)  
 (Severity Level 3 for Air Discharge at 8KV,  
 Severity Level 2 for Contact Discharge at 4KV)

### 13.3. Severity Levels and Performance Criterion

#### 13.3.1. Severity level

Level	Test Voltage Contact Discharge (KV)	Test Voltage Air Discharge (KV)
1.	2	2
2.	4	4
3.	6	8
4.	8	15
X	Special	Special

#### 13.3.2. Performance criterion : **B**

### 13.4. Test Procedure

#### 13.4.1. Air Discharge:

The test was applied on non-conductive surfaces of EUT. The round discharge tip of the discharge electrode was approached as fast as possible to touch the EUT. After each discharge, the discharge electrode was removed from the EUT. The generator was re-triggered for a new single discharge and repeated 20 times for each pre-selected test point. This procedure was repeated until all the air discharge completed

#### 13.4.2. Contact Discharge:

All the procedure was same as Section 12.4.1. except that the generator was re-triggered for a new single discharge and repeated 50 times for each pre-selected test point. the tip of the discharge electrode was touch the EUT before the discharge switch was operated.

### 13.5. Test Results

#### 13.5.1. Test Results: **PASS**

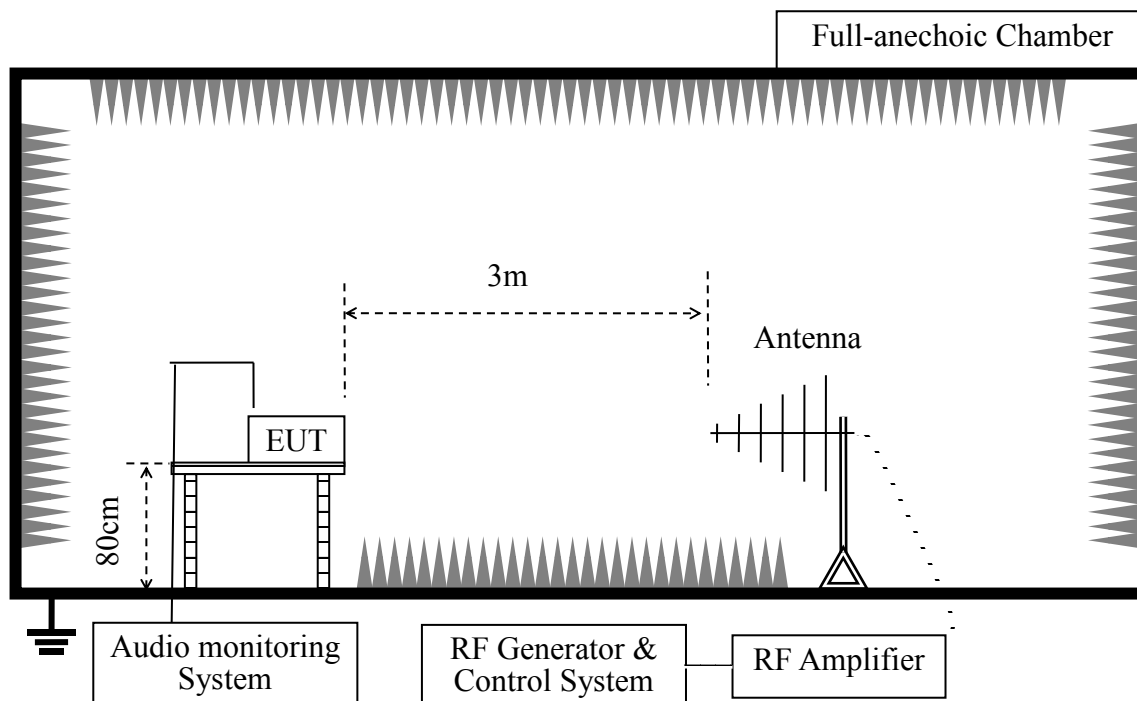
#### 13.5.2. Test data on the following pages.





## 14. RF FIELD STRENGTH SUSCEPTIBILITY TEST

### 14.1. Configuration of Test System



### 14.2. Test Standard

EN 55035:2017+A11:2020 (IEC 61000-4-3:2006+A1:2007+A2:2010)  
(Severity Level: 2 at 3V / m)

### 14.3. Severity Levels and Performance Criterion

Basic Standard:	IEC 61000-4-3
Required Performance:	A
Frequency Range:	80 MHz - 1000 MHz, 1800MHz, 2600MHz, 3500MHz, 5000MHz
Field Strength:	3 V/m
Modulation:	1kHz Sine Wave, 80%, AM Modulation
Frequency Step:	1 % of fundamental
Polarity of Antenna:	Horizontal and Vertical
Test Distance:	3 m
Antenna Height:	1.5 m
Dwell Time:	at least 3 seconds

#### 14.4. Test Procedure

- a. The testing was performed in a fully anechoic chamber. The transmit antenna was located at a distance of 3 meters from the EUT.
- b. The frequency range is swept from 80 MHz to 1000 MHz, 1800 MHz, 2600 MHz, 3500 MHz, 5000 MHz, with the signal 80% amplitude modulated with a 1kHz sine-wave. The rate of sweep did not exceed  $1.5 \times 10^{-3}$  decade/s, where the frequency range is swept incrementally, the step size was 1% of preceding frequency value.
- c. The dwell time at each frequency shall be not less than the time necessary for the EUT to be able to respond.
- e. The test was performed with the EUT exposed to both vertically and horizontally polarized fields on each of the four sides.

#### 14.5. Test Results

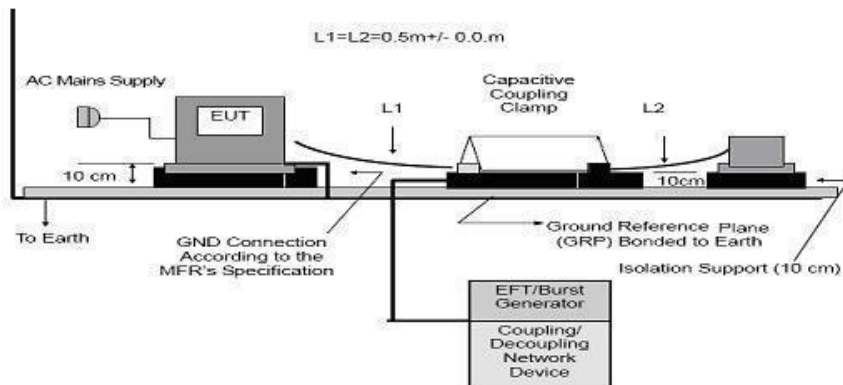
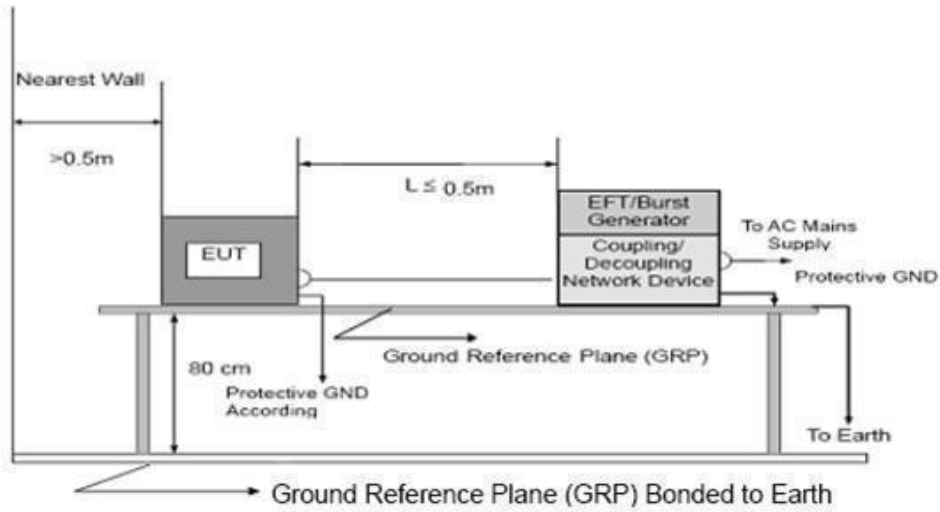
14.5.1. Test Results: **PASS**

14.5.2. Test data on the following pages.



# 15. ELECTRICAL FAST TRANSIENT/BURST IMMUNITY TEST

## 15.1. Configuration of Test System



## 15.2. Test Standard

EN 55035:2017+A11:2020(IEC 61000-4-4:2012)  
(Severity Level 2 at 1KV)

## 15.3. Severity Levels and Performance Criterion

### 15.3.1. Severity level

Open Circuit Output Test Voltage $\pm 10\%$		
Level	On Power Supply Lines	On I/O (Input/Output) Signal data and control lines
1.	0.5 KV	0.25 KV
2.	1 KV	0.5 KV
3.	2 KV	1 KV
4.	4 KV	2 KV
X	Special	Special

15.3.2. Performance criterion : **B**

15.4. Test Procedure

The EUT and its simulators were placed on a the ground reference plane and were insulated from it by an wood support  $0.1\text{m} \pm 0.01\text{m}$  thick. The ground reference plane was  $1\text{m} \times 1\text{m}$  metallic sheet with 0.65mm minimum thickness. This reference ground plane was project beyond the EUT by at least 0.1m on all sides and the minimum distance between EUT and all other conductive structure, except the ground plane was more than 0.5m. All cables to the EUT was placed on the wood support, cables not subject to EFT/B was routed as far as possible from the cable under test to minimize the coupling between the cables.

15.4.1. For input and AC power ports:

The EUT was connected to the power mains by using a coupling device which couples the EFT interference signal to AC power lines. Both positive transients and negative transients of test voltage was applied during compliance test and the duration of the test can't less than 2mins.

15.4.2. For signal lines and control lines ports:

It's unnecessary to test.

15.4.3. For DC input and DC output power ports:

It's unnecessary to test.

15.5. Test Results

15.5.1. Test Results: **PASS**

15.5.2. Test data on the following pages.

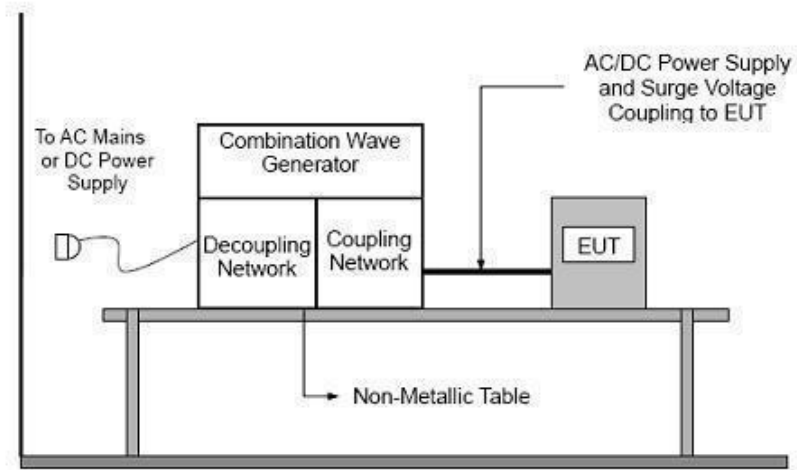
*Electrical Fast Transient/Burst Test Results*  
Shenzhen Most Technology Service Co., Ltd.

Test Voltage :	1	Test Date :	Sep.03,2021
----------------	---	-------------	-------------



# 16.SURGE TEST

## 16.1.Configuration of Test System



## 16.2.Test Standard

EN 55035:2017+A11:2020 (IEC 61000-4-5:2005)  
 (Severity Level : Line to Line was Level 2 at 1KV  
 Line to PE was Level 3 at 2KV)

## 16.3.Severity Levels and Performance Criterion

### 16.3.1.Severity level

Severity Level	Open-Circuit Test Voltage KV
1	0.5
2	1.0
3	2.0
4	4.0
*	Special

### 16.3.2.Performance criterion : **B**



## 16.4. Test Procedure

16.4.1. Set up the EUT and test generator as shown on Section 15.1.

16.4.2. For line to line coupling mode, provide a 1KV 1.2/50us voltage surge (at open-circuit condition) and 8/20us current surge to EUT selected points, and for active line / neutral line to ground are same except test level is 2KV.

16.4.3. At least 5 positive and 5 negative (polarity) tests with a maximum 1/min repetition rate are applied during test.

16.4.4. Different phase angles are done individually.

16.4.5. Record the EUT operating situation during compliance test and decide the EUT immunity criterion for above each test.

## 16.5. Test Results

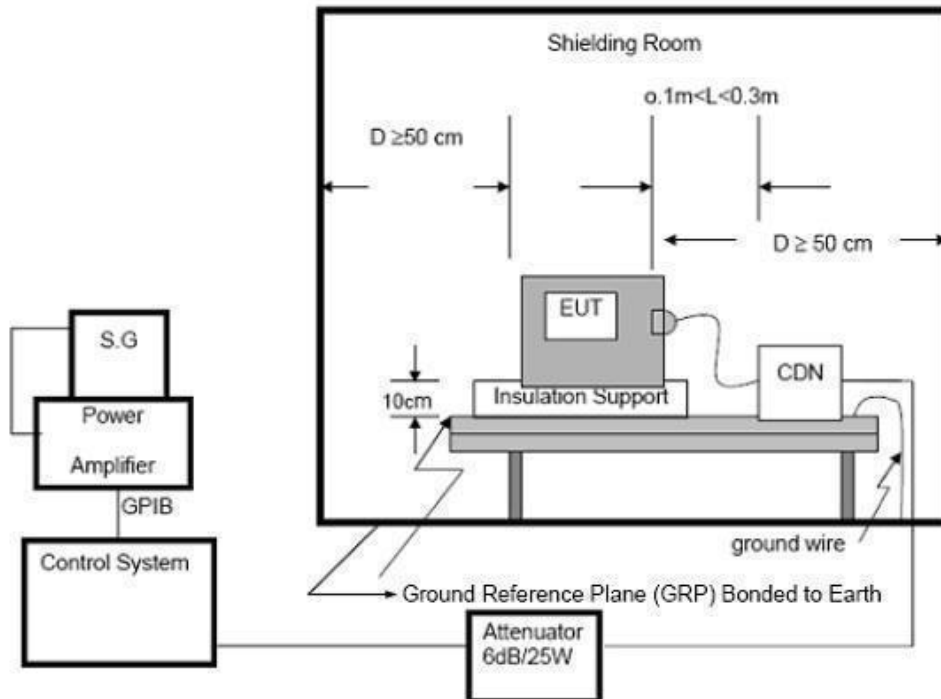
16.5.1. Test Results: **PASS**

16.5.2. Test data on the following pages.



## 17. INJECTED CURRENTS SUSCEPTIBILITY TEST

### 17.1. Configuration of Test System



### 17.2. Test Standard

EN 55035:2017+A11:2020(IEC 61000-4-6:2008)

(Severity Level 2 at 3V (r.m.s.) and frequency is from 0.15MHz to 10MHz)

Severity Level 1 & Level 2 at 3V (r.m.s.) to 1V (r.m.s.) and frequency is from 10MHz to 30MHz

Severity Level 1 at 1V (r.m.s.) and frequency is from 30MHz to 80MHz)

### 17.3. Severity Levels and Performance Criterion

#### 17.3.1. Severity level

Level	Voltage Level (e.m.f.) V
1.	1
2.	3
3.	10
X	Special

#### 17.3.2. Performance criterion: A

## 17.4. Test Procedure

- 17.4.1. Set up the EUT, CDN and test generators as shown on Section 16.1.
- 17.4.2. Let the EUT work in test mode and test it.
- 17.4.3. The EUT are placed on an insulating support 0.1m high above a ground reference plane. CDN (coupling and decoupling device) is placed on the ground plane about 0.3m from EUT. Cables between CDN and EUT are as short as possible, and their height above the ground reference plane shall be between 30 and 50 mm (where possible).
- 17.4.4. The disturbance signal description below is injected to EUT through CDN.
- 17.4.5. The EUT operates within its operational mode(s) under intended climatic conditions after power on.
- 17.4.6. Recording the EUT operating situation during compliance testing and decide the EUT immunity criterion.

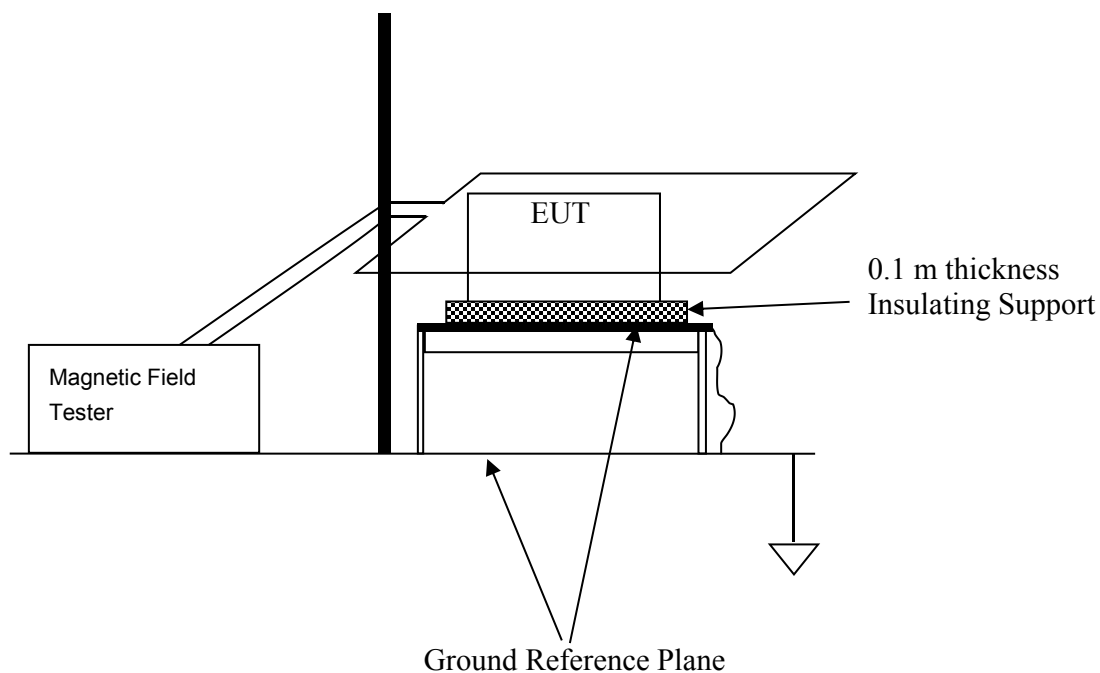
## 17.5. Test Results

- 17.5.1. Test Results: **PASS**
- 17.5.2. Test data on the following pages.



# 18. MAGNETIC FIELD IMMUNITY TEST

## 18.1. Configuration of Test System



## 18.2. Test Standard

EN 55035:2017+A11:2020(IEC 61000-4-8:2009)  
(Severity Level 1 at 1A/m)

## 18.3. Severity Levels and Performance Criterion

### 18.3.1. Severity level

Level	Magnetic Field Strength A/m
1.	1
2.	3
3.	10
4.	30
5.	100
X.	Special

### 18.3.2. Performance criterion : A

## 18.4. Test Procedure

The EUT was subjected to the test magnetic field by using the induction coil of standard dimensions (1m\*1m) and shown in Section 17.1. The induction coil was then rotated by 90° in order to expose the EUT to the test field with different orientations.

## 18.5. Test Results

18.5.1. Test Results: **PASS**

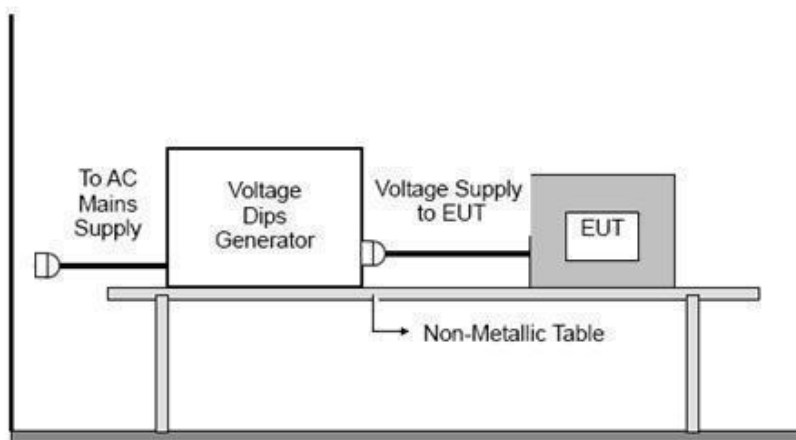
18.5.2. Test data on the following pages.





# 19. VOLTAGE DIPS AND INTERRUPTIONS TEST

## 19.1. Configuration of Test System



## 19.2. Test Standard

EN 55035:2017+A11:2020(IEC 61000-4-11:2004)

(Severity level: 0%      250 period  
                           0%      0.5 periods  
                           70%     25 periods )

## 19.3. Severity Levels and Performance Criterion

### 19.3.1. Severity level

Test Level %U <sub>T</sub>	Voltage dip and short interruptions %U <sub>T</sub>	Performance Criterion	Duration (in period)
0	100	C	250
0	100	B	0.5
70	30	C	25

### 19.3.2. Performance criterion : B & C

## 19.4. Test Procedure

19.4.1. The EUT and test generator were setup as shown on Section 18.1.

19.4.2. The interruptions is introduced at selected phase angles with specified duration.

19.4.3. Record any degradation of performance.

## 19.5. Test Results

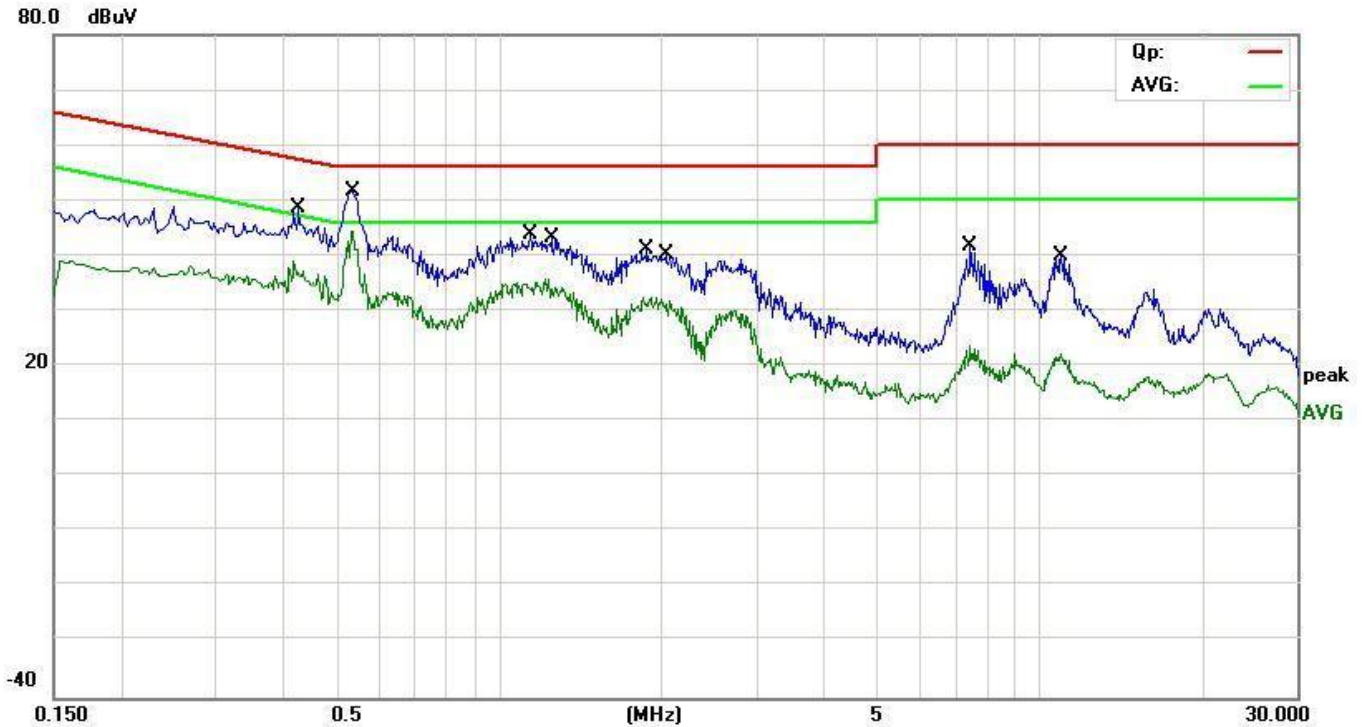
19.5.1. Test Results: PASS

19.5.2. Test data on the following pages.



# **APPENDIX I**

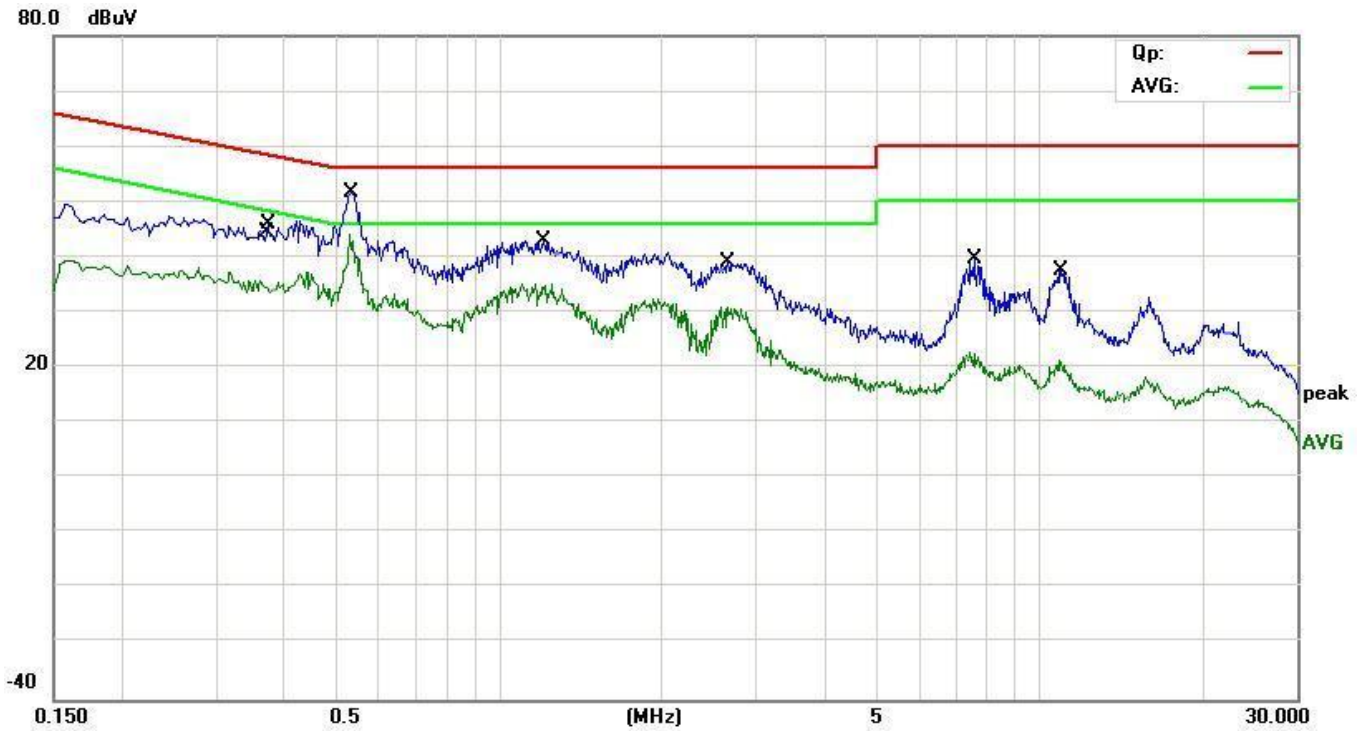
EUT:	DVR	M/N:	TD-2708NS-HC
Mode:	Running	Phase:	L
Test by:	Peter	Power:	DC 12V by Adapter
Temperature: / Humidity	23.0°C / 54.0%	Test date:	2021-09-02



No.	Mk.	Freq. MHz	Reading Level dBuV	Correct Factor dB	Measure- ment dBuV	Limit dBuV	Over dB	Detector	Comment
1		0.4220	26.96	9.59	36.55	47.41	-10.86	AVG	
2		0.4260	39.05	9.59	48.64	57.33	-8.69	QP	
3		0.5380	42.04	9.59	51.63	56.00	-4.37	QP	
4	*	0.5380	32.80	9.59	42.39	46.00	-3.61	AVG	
5		1.1460	34.35	9.60	43.95	56.00	-12.05	QP	
6		1.2380	26.15	9.60	35.75	46.00	-10.25	AVG	
7		1.8500	22.81	9.60	32.41	46.00	-13.59	AVG	
8		2.0420	30.50	9.60	40.10	56.00	-15.90	QP	
9		7.4740	32.20	9.66	41.86	60.00	-18.14	QP	
10		7.4740	14.03	9.66	23.69	50.00	-26.31	AVG	
11		10.9820	30.21	9.69	39.90	60.00	-20.10	QP	
12		10.9820	12.56	9.69	22.25	50.00	-27.75	AVG	

\*:Maximum data    x:Over limit    !:over margin

EUT:	DVR	M/N:	TD-2708NS-HC
Mode:	Running	Phase:	N
Test by:	Peter	Power:	DC 12V by Adapter
Temperature: / Humidity	23.0°C / 54.0%	Test date:	2021-09-02

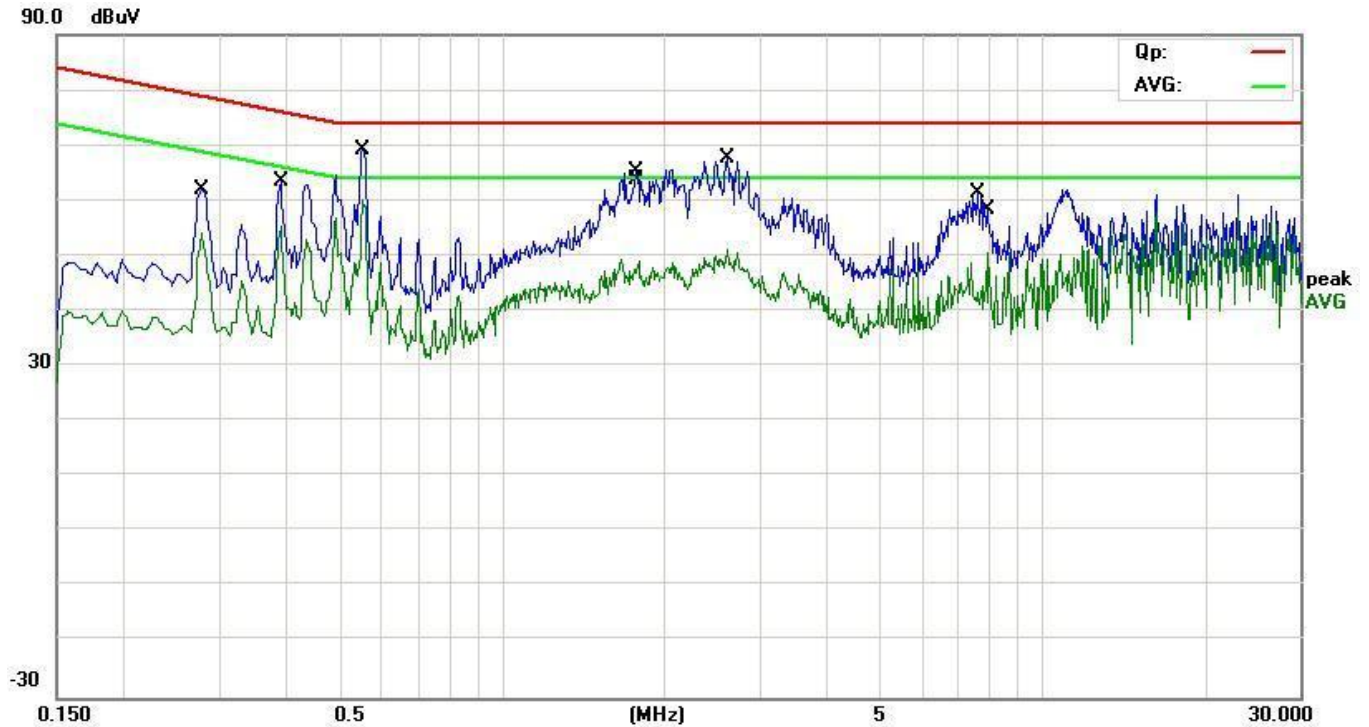


No.	Mk.	Freq. MHz	Reading Level dBuV	Correct Factor dB	Measure- ment dBuV	Limit dBuV	Over dB	Detector	Comment
1		0.3673	25.13	9.59	34.72	48.56	-13.84	AVG	
2		0.3740	36.43	9.59	46.02	58.41	-12.39	QP	
3		0.5300	32.00	9.59	41.59	46.00	-4.41	AVG	
4	*	0.5340	42.09	9.59	51.68	56.00	-4.32	QP	
5		1.2100	33.37	9.60	42.97	56.00	-13.03	QP	
6		1.2180	25.17	9.60	34.77	46.00	-11.23	AVG	
7		2.6620	29.50	9.61	39.11	56.00	-16.89	QP	
8		2.6620	21.39	9.61	31.00	46.00	-15.00	AVG	
9		7.4780	13.14	9.66	22.80	50.00	-27.20	AVG	
10		7.5980	29.98	9.66	39.64	60.00	-20.36	QP	
11		10.8540	11.52	9.69	21.21	50.00	-28.79	AVG	
12		10.9740	27.99	9.69	37.68	60.00	-22.32	QP	

\*:Maximum data    x:Over limit    !:over margin

## **APPENDIX II**

EUT:	DVR	M/N:	TD-2708NS-HC
Mode:	Ping	Polarization:	CAT5
Test by:	Peter	Power:	DC 12V by Adapter
Temperature: / Humidity	23.0°C / 54.0%	Test date:	2021-09-02



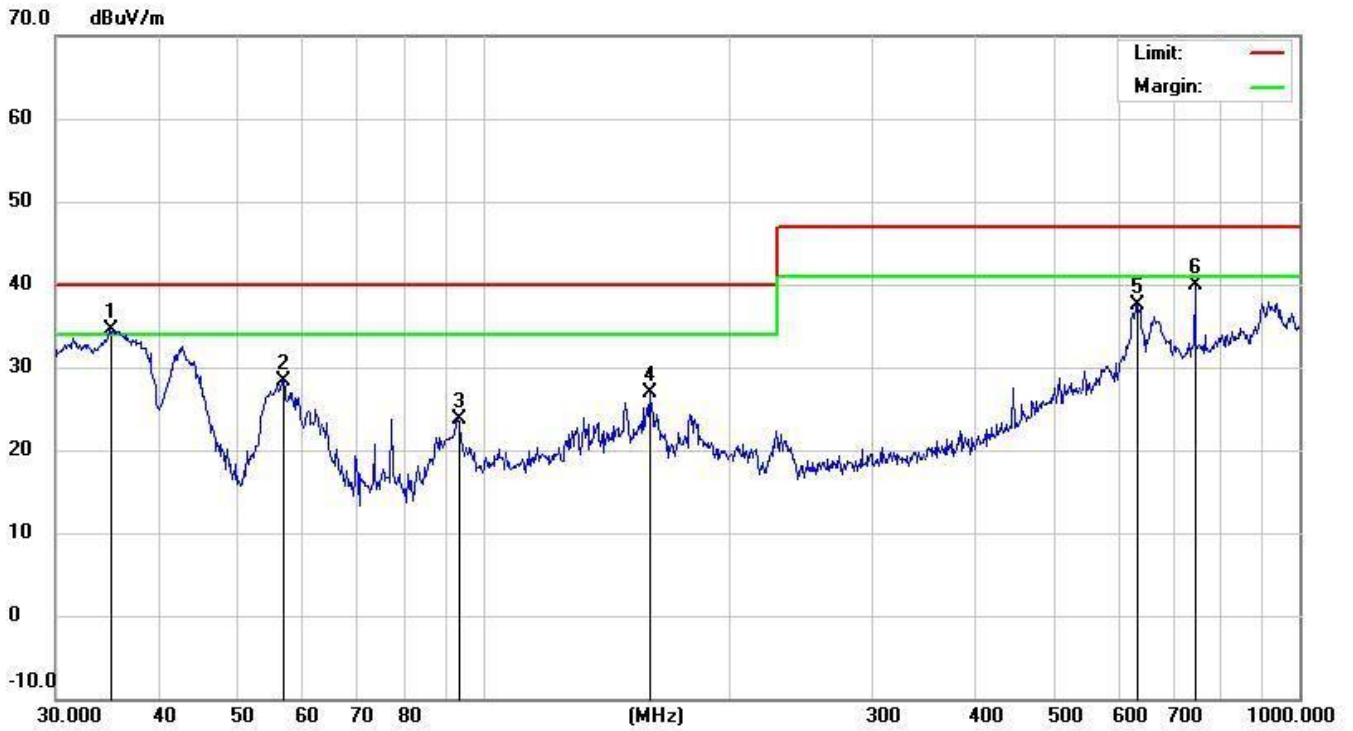
No.	Mk.	Freq. MHz	Reading Level dBuV	Correct Factor dB	Measure- ment dBuV	Limit dBuV	Over dB	Detector	Comment
1		0.2780	52.48	9.59	62.07	78.88	-16.81	QP	
2		0.2780	44.54	9.59	54.13	68.88	-14.75	AVG	
3		0.3900	53.75	9.59	63.34	76.06	-12.72	QP	
4		0.3900	45.70	9.59	55.29	66.06	-10.77	AVG	
5		0.5540	59.57	9.59	69.16	74.00	-4.84	QP	
6	*	0.5540	50.53	9.59	60.12	64.00	-3.88	AVG	
7		1.7740	55.77	9.60	65.37	74.00	-8.63	QP	
8		1.7940	39.49	9.60	49.09	64.00	-14.91	AVG	
9		2.6100	57.92	9.61	67.53	74.00	-6.47	QP	
10		2.6100	41.66	9.61	51.27	64.00	-12.73	AVG	
11		7.6100	51.57	9.66	61.23	74.00	-12.77	QP	
12		7.9260	41.03	9.66	50.69	64.00	-13.31	AVG	

\*:Maximum data    x:Over limit    !:over margin



## **APPENDIX III**

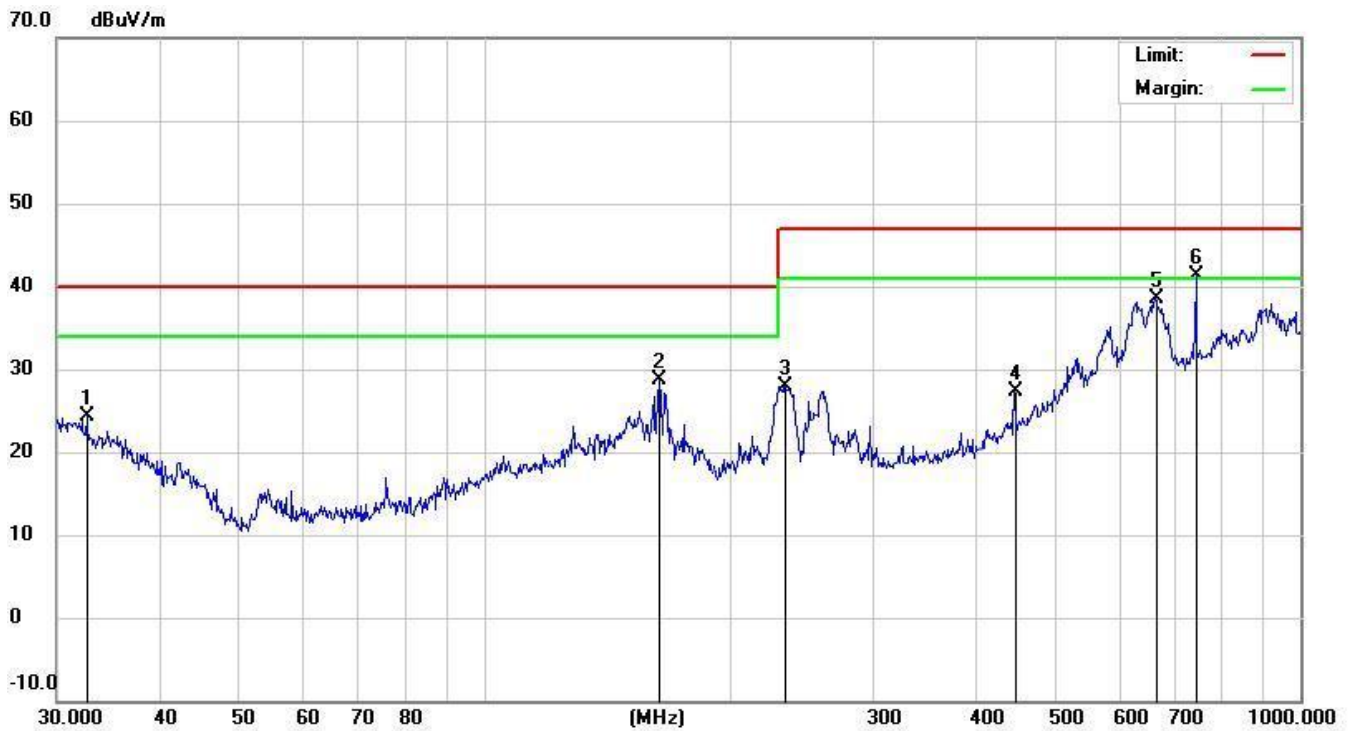
EUT:	DVR	M/N:	TD-2708NS-HC
Mode:	Running	Polarization:	Vertical
Test by:	LEO	Power:	DC 12V by Adapter
Temperature: / Humidity	25.0°C / 53.0%	Test date:	2021-09-02



No.	Mk.	Freq. MHz	Reading Level dBuV	Correct Factor dB	Measure- ment dBuV/m	Limit dBuV/m	Over dB	Detector	Antenna Height cm	Table Degree	Comment
1	*	34.8823	16.86	17.58	34.44	40.00	-5.56	QP			
2		56.9912	19.91	8.45	28.36	40.00	-11.64	QP			
3		93.1132	12.73	11.05	23.78	40.00	-16.22	QP			
4		160.3456	9.62	17.29	26.91	40.00	-13.09	QP			
5		631.6884	13.35	24.21	37.56	47.00	-9.44	QP			
6		744.8661	13.54	26.36	39.90	47.00	-7.10	QP			

\*:Maximum data    x:Over limit    !:over margin

EUT:	DVR	M/N:	TD-2708NS-HC
Mode:	Running	Polarization:	Horizontal
Test by:	LEO	Power:	DC 12V by Adapter
Temperature: / Humidity	25.0°C/ 53.0%	Test date:	2021-09-02



No.	Mk.	Freq.	Reading Level	Correct Factor	Measurement	Limit	Over	Antenna Height	Table Degree
		MHz	dBuV	dB	dBuV/m	dBuV/m	dB	cm	degree
1		32.6340	5.16	19.11	24.27	40.00	-15.73		
2		164.3301	11.53	17.16	28.69	40.00	-11.31		
3		233.3487	13.65	14.27	27.92	47.00	-19.08		
4		446.4141	7.37	19.86	27.23	47.00	-19.77		
5		663.4729	13.97	24.63	38.60	47.00	-8.40		
6	*	744.8661	14.91	26.36	41.27	47.00	-5.73		

\*:Maximum data    x:Over limit    !:over margin

**APPENDIX IV**  
(Test Photos)

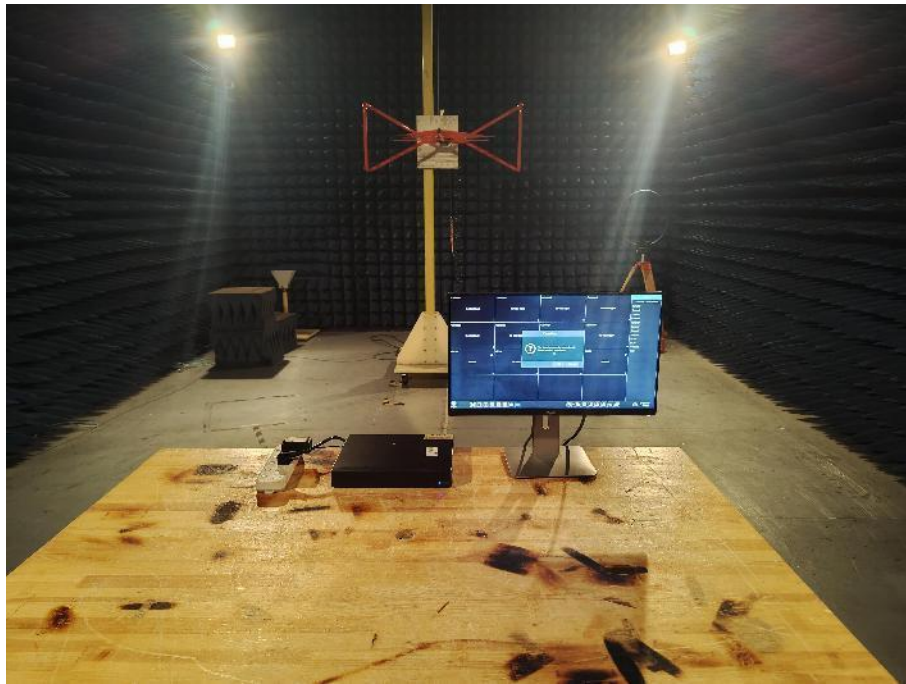
## Conducted Test Setup Photograph



## Conducted disturbance at telecommunication ports terminals test Setup Photograph



## Radiated Test Setup Photograph



**APPENDIX V**  
(Photos of the EUT)



**Figure 1**  
General Appearance of the EUT

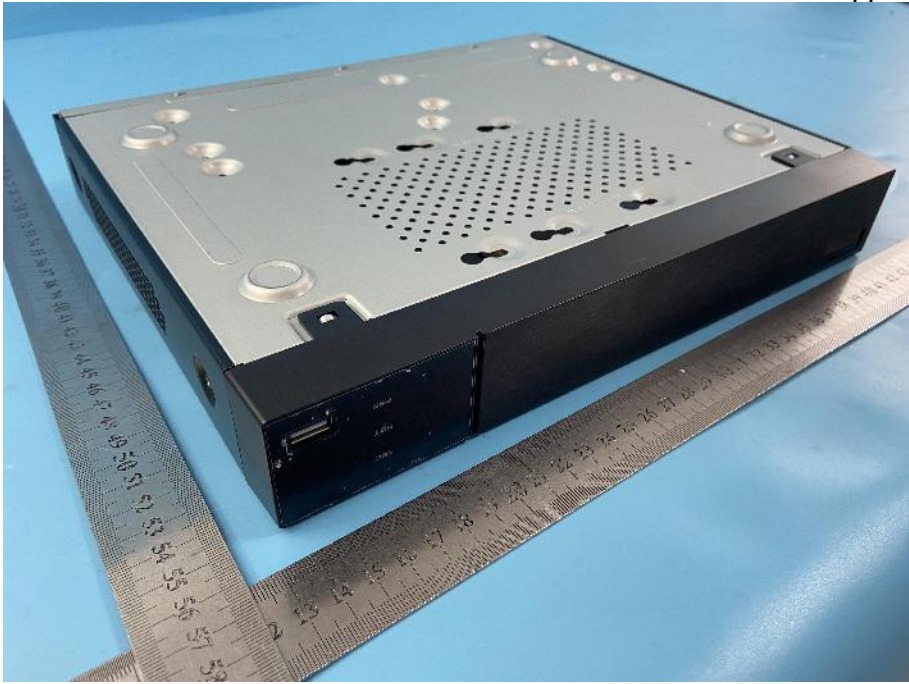


**Figure 2**  
General Appearance of the EUT





**Figure 3**  
General Appearance of the EUT



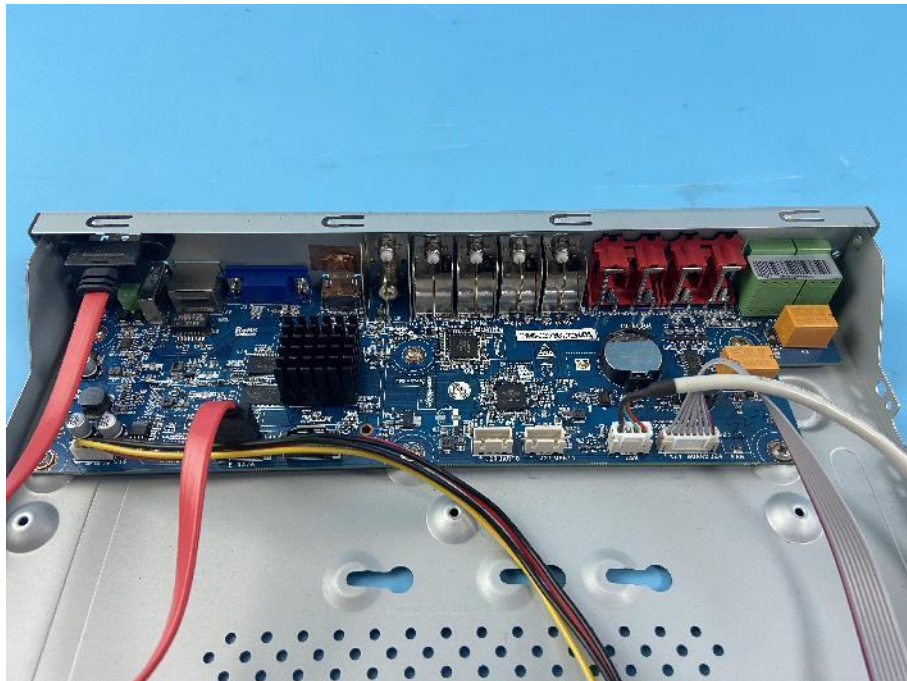
**Figure 4**  
General Appearance of the EUT



**Figure 5**  
Internal of the EUT

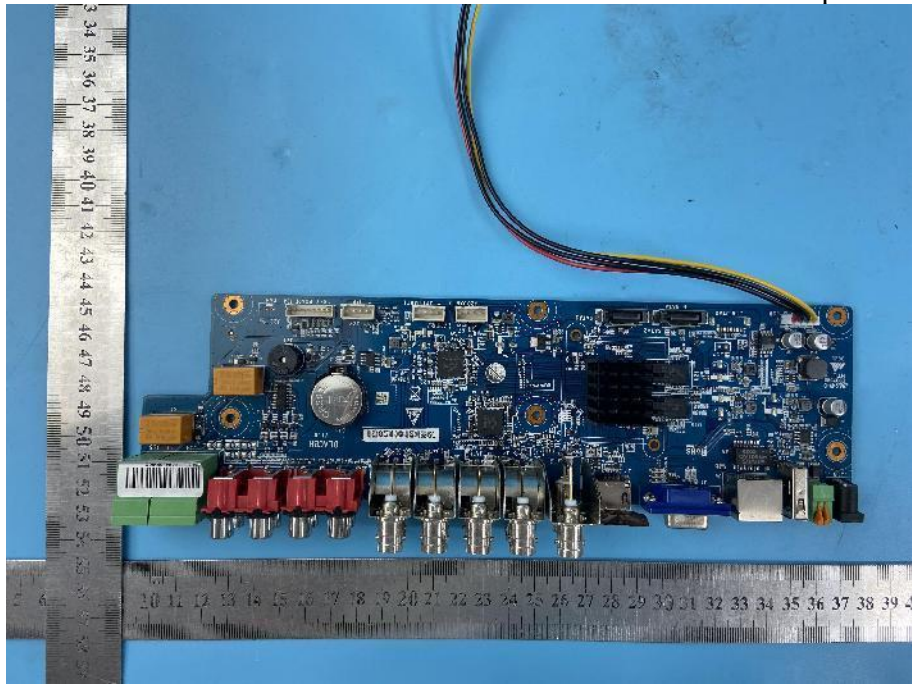


**Figure 6**  
Internal of the EUT



**Figure 7**

Components Side of the PCB



**Figure 8**  
Components Side of the PCB

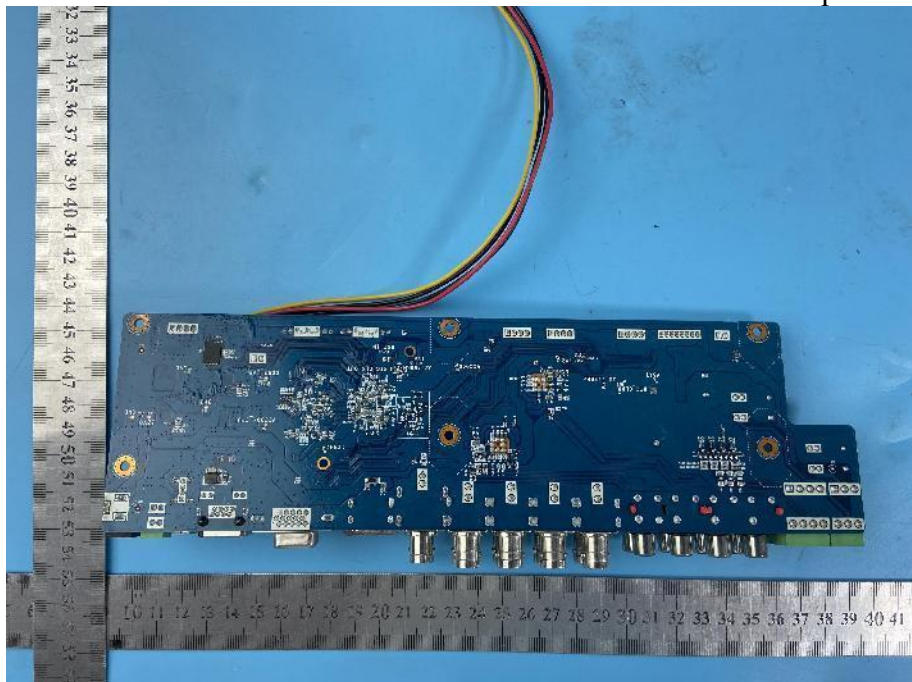




Figure 9  
Adapter of the EUT

